

SELF-ALIGNING SWIVEL JOINTS

BARCO Standard Series

Standard Series Self-Aligning Swivel Joints are built for steam, hot oil, water and alternating steam and water service.

- Available in four styles in all bronze, 3/8"(10mm) to 3/4"(20mm) sizes, or in malleable iron casing with bronze nut and ball, 1/2"(15mm) to 2"(50mm) sizes.
- Working pressure to 175 psi(12 kg/cm²) and temperature to 400° F (204° C) with the 11 CTS (-23) gasket.
- Rated 323 psi(23 kg/cm²) when equipped with the 11 GCTS (-24)gasket.
- Available from stock in 3/8" (10mm) to 2" (50mm).

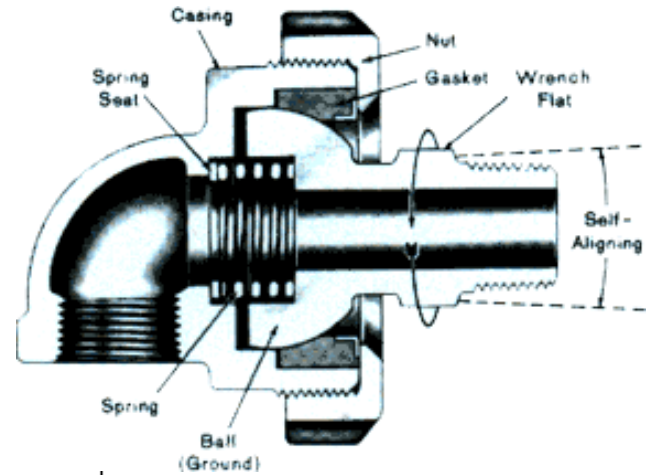

STANDARD SERIES

Bronze and Malleable Iron

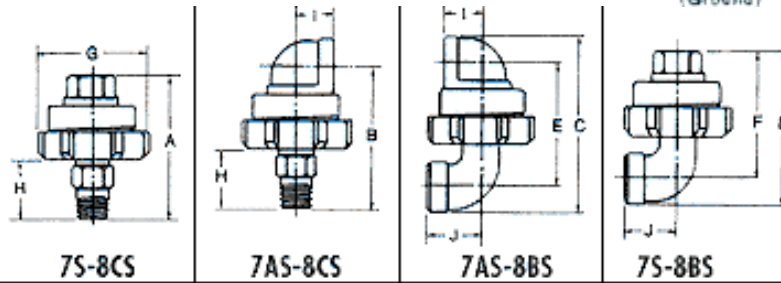

Basic Assembly Number

All bronze*	BE32001	BE32003	BE32002	BE32000
Malleable iron casing with bronze ball**	BE32008	BE32011	BE32010	BE32007

Available in 1/2" (15mm) to 3/4" (20mm) sizes, inclusive.

Available in 1/2" (15mm) to 1-1/2" (40mm) in malleable iron casing with bronze nut and ball.

Dimension Data/Standard Series - in./mm

Joint Size	Size Code	A	B	C	D	E	F	G	H	I	J
1/2" 15mm	08	3.38 86	3.38 86	4.24 108	3.63 92	3.04 77	3.04 77	2.58 66	1.32 34	.97 25	1.19 30
3/4" 20mm	12	3.80 96	3.77 96	5.26 134	4.48 114	3.64 92	3.67 93	3.62 92	1.42 36	1.19 30	1.31 33
1" 25mm	16	4.69 119	4.16 106	6.00 152	5.57 141	4.10 104	4.63 118	3.94 100	1.63 41	1.50 38	1.50 38
1-1/4" 32mm	20	4.89 124	4.70 119	7.34 186	6.31 160	5.06 129	5.25 133	4.19 106	1.59 40	1.69 43	1.81 46
1-1/2" 40mm	24	5.56 141	5.44 138	7.56 192	6.44 164	5.06 129	5.18 132	5.00 127	2.15 54	2.16 55	2.30 58

BARCO Series 600

Series 600 Self-Aligning Swivel Joints are designed for high pressure hydraulic service, alternating high pressure water and steam. service.

- Available in four styles in all steel fabrication.
- Pressures to 400 psi(28 kg/cm²) and temperature to 450° F (232° C) in steam service.
- Available from stock in 1-1/4" (32mm) to 1-1/2" (40mm).

600 SERIES all steel

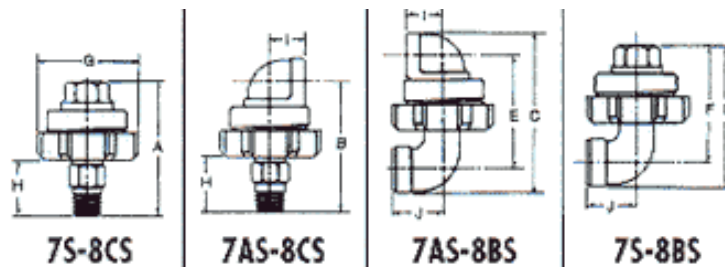

Basic Assembly Number

BE33004	BE33008	BE33010	BE33006
----------------	----------------	----------------	----------------

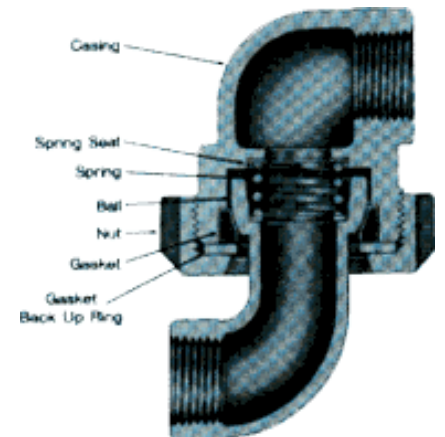

Dimension Data/600 Series - in./mm

Joint Size	Size Code	A	B	C	D	E	F	G	H	I	J
1-1/4" 32mm	20	5.38 137	5.29 134	7.54 192	6.41 163	5.29 134	5.35 136	5.12 130	1.88 48	2.03 52	2.12 54
1-1/2" 40mm	24	6.23 158	6.19 157	8.55 217	7.24 184	6.03 153	6.04 153	5.38 137	2.25 57	2.25 57	2.62 67

BARCO Series 600
w/Injectable Flaked Graphite Sealant

These joints, with injectable graphite sealant, are designed for hot oil and high pressure steam applications. They are especially attractive for hardboard platen presses.

- Sealant can be recharged without removing joint from machine.
- No disassembly required for maintenance.
- Saves expense on downtime and maintenance.
- Hot Oil pressures to 200 psig(14 kg/cm²) and temperatures to 650° F (343° C).
- Live steam pressures to 700 psig(49 kg/cm²) and temperatures to 500° F (260° C).
- Available in 1-1/4"(32mm), 1-1/2"(40mm) with socket weld ends.

600 SERIES
all steel
w/injectable graphite seal

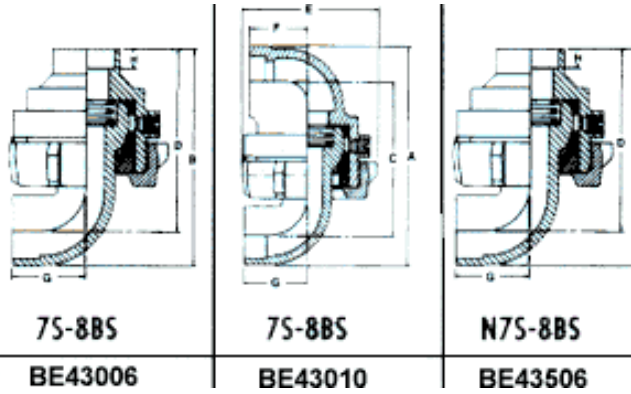

Dimension Data/600 Series w/injectable graphite seal -in./mm

Joint Size	Size Code	A	B	C	D	E	F	G	H
1-1/4" 32mm	20	7.50 191	6.40 163	5.25 133	5.34 136	5.12 130	2.03 52	2.12 54	.56 14
1-1/2" 40mm	24	8.67 220	7.60 193	6.12 155	6.38 162	5.38 137	2.31 59	2.69 68	.50 13